



Standby 30 kW, 38 kVA
 Prime 27 kW, 35 kVA
 60 Hz

Image shown may not reflect actual configuration

Specifications

Frequency	Voltage	Standby kW (kVA)	Prime kW (kVA)	Speed rpm
60 Hz	480/277V	30 (38)	27 (35)	1800
60 Hz	208/120V	30 (38)	27 (35)	1800
60 Hz	240/120V	30 (30)	27 (27)	1800

Cat® C2.2 Diesel Engine	Metric	Imperial (English)
Configuration	I-4, 4-Stroke Diesel	
Bore	84 mm	3.3 in
Stroke	100 mm	3.9 in
Displacement	2.2 L	135 in ³
Aspiration	ATAAC	
Compression Ratio	18:1	
Engine Speed	1800 rpm	
Governor Type	Electronic	
Governor Class	ISO8528 G1 and G2	
Maximum power at rated speed – bkW (hp)		
Standby	36.4	(49)
Prime	32.8	(44)

Benefits & Features

Fuel/Emissions Strategy

- Meets U.S. EPA Tier 4 Final emission standards and CARB certified for non-road mobile applications at all 60 Hz ratings

Cat C2.2T Diesel Engine

- Four-stroke diesel engine combines performance and excellent fuel economy with minimum weight
- On-engine aftertreatment consists of NOx Reduction System (NRS) and Diesel Oxidation Catalyst (DOC) for service-free operation
- 500-hour oil change interval
- Common rail direct injection
- Electronic engine controls
- Engine block heater 110-120 VAC

Cat LC Series Generator

- Matched to the performance and output characteristics of Cat diesel engines
- Class H Insulation

Cat EMCP 4.2B Control Panel

- Electronic control panel provides power metering, protective relaying, engine and generator parameter viewing, and expanded AC metering.
- Graphical display (3.8 in.) denotes text alarm/event descriptions, set points, engine and generator monitoring, and is visible in all lighting conditions.
- Simple, user-friendly interface and navigation
- Integrates with the Cat Integrated Voltage Regulator (IVR) to provide precise control, excellent block loading, and constant voltage

Environmentally Friendly Design

- 110% spill containment of all engine fluids
- Nonmetallic fuel tank provides >24-hour run time at 75% prime load
- Two-way valve and external fuel ports to easily switch between on-board and external fuel source
- Two-speed, electric cooling fans for reduced fuel consumption and reduced sound (63 dBA at 7 m)
- Solar battery maintainer

Sound-attenuated Enclosure

- Rugged, corrosion-resistant construction:
 - Galvanealed, sheet steel body panels with zinc phosphate pretreatment prior to polyester powder coating
 - Die-cast aluminum hinges with SST pins
- Excellent access for service and maintenance:
 - Two doors on each side, and one rear door for power distribution and control panel access
 - Lift-off door hinges for easy door removal
 - Lube oil and coolant drains piped to exterior of the enclosure
- Security and safety features:
 - Control panel located behind rear access door with safety-glass viewing window
 - Padlockable latches on all access doors
 - Exterior emergency stop (E-stop) button

Controls and Power Distribution

- Three-position switch for easy selection of desired output (480/277V 3-phase, 208/120V 3-phase, or 240/120V single phase)
- Controls, sockets, and power distribution all accessible via rear access door
- Hinged door over main bus bars with safety switch to trip breaker

Asset Monitoring and Management (Available 3Q2016)

- Product Link™ Generation (PLG) hardware provides two-way communication for remote control and equipment monitoring via cellular network
- Customer-defined, equipment-based real-time status updates and alerts
- Flexible and customer-configurable user interface
- GPS provides asset location and geo-fencing

Options

- Generator anti-condensation heater
- Battery charger
- Trailer (electric, hydraulic, or no brakes)
- Trailer hitch (2-in. ball, 2-5/16-in. ball, or pintle)
- 600V generator (available 3Q2016)

Standard Equipment

Engine

- Cat C2.2T, heavy-duty, EPA Tier 4 Final certified diesel engine
- NOx and engine-mounted DOC
- Block heater, 110-120 VAC
- Requires Ultra Low Sulfur Diesel (ULSD) fuel
- Engine Electrical System:
 - 12-volt, DC electrical system
 - 85-amp, DC charging alternator
 - Electronic governor and engine controls
 - Oil pressure, coolant temperature, and coolant level shutdown switches
- Engine Filtration System:
 - Cartridge-type air filter with service indicator
 - Cartridge-type fuel filter with upstream pre-filter and water separator,
 - Spin-on, full-flow lube oil filter, requires API CJ-4 lube oil.

Generator and Voltage Regulation

- Screen protected and drip-proof (IP23), self-regulating, 12-lead, 4-pole, brushless generator
- Sealed-for-life bearing
- Electrical design in accordance with IEC60034-1, EN61000-6, NEMA MG-1.22, and CSA
- Self-excited for self protection against short circuits
- Voltage selection switch (3 position) mounted to generator terminal box
- Optional
 - Anti-condensation, space heater, 60-Watt, 110-120 VAC
- Insulation System:
 - Class H insulation system
 - Windings are impregnated in a thermo-setting moisture, oil, and acid resisting varnish
 - Heavy coat of anti-tracking varnish for additional protection against moisture or condensation
- IVR:
 - Simplified operation and troubleshooting
 - Removes duplication of set points
 - Configure IVR parameters and view IVR status screens via the EMCP
 - Fully supported by Cat ET service tool

- Waveform distortion, THF, and TIF Factors:
 - Total distortion of voltage waveform with open circuit between phases, or phase and neutral, on the order of 1.8 Total distortion <4%, on a 3-phase, balanced, harmonic-free load
 - Total distortion <2%, under no load
 - Waveform: NEMA (TIF <50)
 - 2/3 pitch standard on all stator windings

Generator Set Packaging

- Base frame and containment tray
 - Heavy-duty, fabricated steel base frame with specially-designed lifting points
 - Spill containment tray mounted to base frame, with leak-detection switch
- Canopy
 - Sound attenuated to 63 dBA at 7 m (23 ft)
 - Two doors on each side, and one rear door for power distribution and control panel access
 - Die-cast aluminum lift-off hinges with SST pins
- Cooling System:
 - Radiator and two-speed, electric cooling fans (2) complete with protective guards
 - Cooling system provides 43°C (109°F) ambient capability at 500 m (2,460 ft) above sea level
- Electrical System:
 - 12-volt, DC electrical system
 - 880CCA, maintenance-free, wet battery
 - Battery disconnect switch, lockable
 - Solar battery maintainer with solar array
 - Resettable, switch-style circuit breakers (DC circuit)
 - Optional 10A battery charger, 110-120 VAC constant voltage, UL listed
- Engine and generator mounting
 - Engine and generator are directly coupled by an SAE flange
 - Engine flywheel is flexibly coupled to the generator rotor, with full torsional analysis completed to ensure no harmful vibration will occur in the assembly
 - Anti-vibration pads between engine/generator feet and base frame

Standard Equipment (continued)

- Fuel System:
 - Cross-linked polyethylene (XLPE) fuel tank; 55 gallon usable volume
 - 24 hour runtime @ 100% prime load
 - 2-position valves and external ports (1/4-in. NPT) allow connection of an auxiliary fuel source

Generator Controls and Power Distribution

- EMCP 4.2B, digital generator set controller, mounted behind a hinged, lockable door with viewing window
- Circuit Breaker: 3-pole molded case breaker with neutral (4-wire), 125A, UL- and CSA-listed with shunt trip
- Safety switch on hinged main bus cover – trips breaker if cover is opened
- Two-wire, remote start-stop terminals
- Customer auxiliary power connections:
 - Two – 250V, 50A California-style, NEMA, twist lock receptacles

- Two – 120V, 20A duplex receptacles with GFCI*
- Each receptacle is protected by a miniature circuit breaker, which also acts as an on/off switch
- Main customer connections:
 - Tin-plated copper bus bars with phase separators, located behind a protective door with shunt trip switch
 - Bus bars sized for full load capacity of generator set at 0.8 power factor

Quality and Product Support

- Factory load-testing of complete generator set
- Factory test certificate available upon request
- Equipment meets the following standards: BS4999, BS5000, BS5514, IEC60034, EN61000-6, NEMA MG-1.22 & CSA
- Full set of operation and maintenance manuals

*Voltage at receptacle is 120V when switch is in 240/120 and 208 positions, and 139V in 480V position



Technical Data

Cat Generator	
Frame Size	1514J
Pitch	0.6667
No. of poles	4
Insulation	Class H
Enclosure	Drip proof IP23
Voltage regulation	± 0.25% at steady state from no load to full load
Frequency regulation	± 0.25% for constant load from no load to full load
Waveform distortion	THD <4%
Telephone interference	TIF<50, THF<2%
Overspeed limit	2250 rpm
Available voltages	Switchable voltage output: 480/277V, 3-phase; 208/120V, 3-phase; 240/120V, single-phase

Cat Generator Set – 1800 rpm/60 Hz			
	Units	Standby	Prime
Power Rating	kW (kVA)	30 (37.5)	27 (35)
Performance Specification			
Lubricating System			
Total oil	L (gal)	10.6 (2.8)	10.6 (2.8)
Capacity oil	L (gal)	8.9 (2.4)	8.9 (2.4)
Fuel System			
Fuel Consumption** — 100% Load	L/hr (gal/hr)	9.8 (2.6)	8.8 (2.3)
75% Load	L/hr (gal/hr)	7.4 (2.0)	6.7 (1.8)
50% Load	L/hr (gal/hr)	4.9 (1.3)	4.4 (1.2)
Fuel Tank Capacity	L (gal)	208 (55)	208 (55)
Running Time — at 100% Load	Hours	>20	>24
Cooling System			
Radiator system capacity including engine	L (U.S. gal)	9.9 (2.6)	9.9 (2.6)
Heat rejected to coolant at rated power	kW (Btu/min)	29.6 (1,685)	26.6 (1,514)
Air Requirements			
Combustion air flow	m³/min (cfm)	2.2 (76)	2.2 (76)
Radiator cooling air	m³/min (cfm)	86.5 (3,023)	86.5 (3,023)
Generator cooling air	m³/min (cfm)	19.2 (678)	19.2 (678)
Noise Rating** [with enclosure at 7 meters (23 feet)]	dB(A)	63	63

**Package fuel consumption and sound levels are for reference only.

Technical Data (continued)

Dimensions and Weights					
Model	Length mm (in)	Width mm (in)	Height mm (in)	With Lube Oil & Coolant kg (lb)	With Fuel, Lube Oil, & Coolant kg (lb)
XQ35	2318 (91.3)	1050 (41.4)	1617 (63.7)	1003 (2215)	1178 (2600)
XQ35 with trailer (no brakes)	3454 (136.0)	1687 (66.4)	1883 (74.1)	1154 (2555)	1332 (2940)
XQ35 with trailer (electric brakes)	3454 (136.0)	1687 (66.4)	1883 (74.1)	1166 (2575)	1341 (2960)
XQ35 with trailer (hydraulic brakes)	3534 (139.1)	1687 (66.4)	1883 (74.1)	1171 (2585)	1345 (2970)

General Layout Dimensions

Dimensions in millimeters (inches).
Shown with optional trailer.

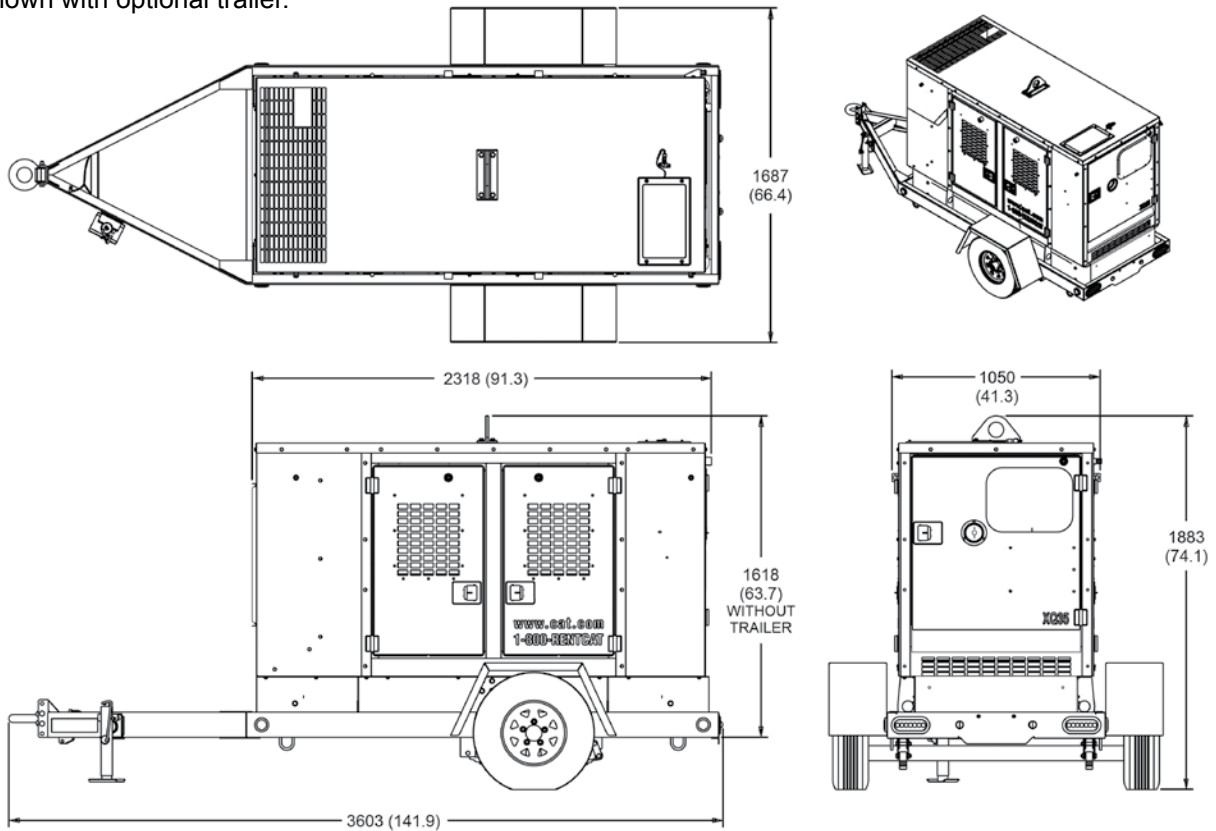

Control Panel and Power Distribution Layout

Item	Description
1	Steel enclosure with hinged, lockable door (not shown)
2	Circuit breakers for receptacles
3	Emergency stop
4	Single-phase GFCI duplex receptacles (20A @ 120V)
5	Two-wire remote start terminals
6	Single-phase, California-style, twist-lock receptacles, 50A @ 208V phase-to-phase, 120V phase to neutral, or 240/120 single phase when in that voltage position
7	Single-phase NEMA locking input receptacle (30A @ 120V) to power block heater, battery charger, and generator space heater
8	Glow plug lamp
9	EMCP 4.2B digital generator set controller
10	Cat ET service tool connector
11	Circuit breaker, 3-pole molded case, 125A
12	Main bus connection (bus bars with 13 mm holes) behind hinged cover with safety switch

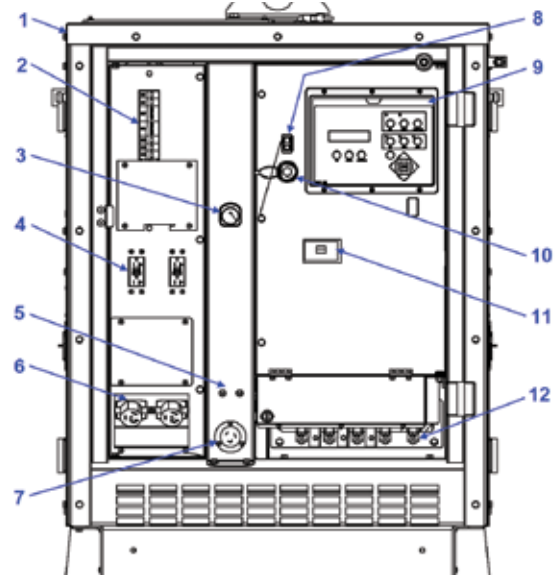

Rating Definitions and Conditions

Standby — Output available with varying load for the duration of the interruption of the normal source power. Average power output is 70% of the standby power rating. Typical operation is 200 hours per year, with maximum expected usage of 500 hours per year.

Prime — Output available with varying load for an unlimited time. Average power output is 70% of the prime power rating. Typical peak demand is 100% of prime rated kW with 10% overload capability for emergency use for a maximum of 1 hour in 12. Overload operation cannot exceed 25 hours per year.

www.Cat.com/rentalpower

©2016 Caterpillar
All rights reserved.

Materials and specifications are subject to change without notice.
The International System of Units (SI) is used in this publication.

CAT, CATERPILLAR, their respective logos, ACERT, Product Link, "Caterpillar Yellow", the "Power Edge" trade dress as well as corporate and product identity used herein, are trademarks of Caterpillar and may not be used without permission.